

BauBuche Flooring beech laminated veneer lumber

Versatile Natural Wood Flooring

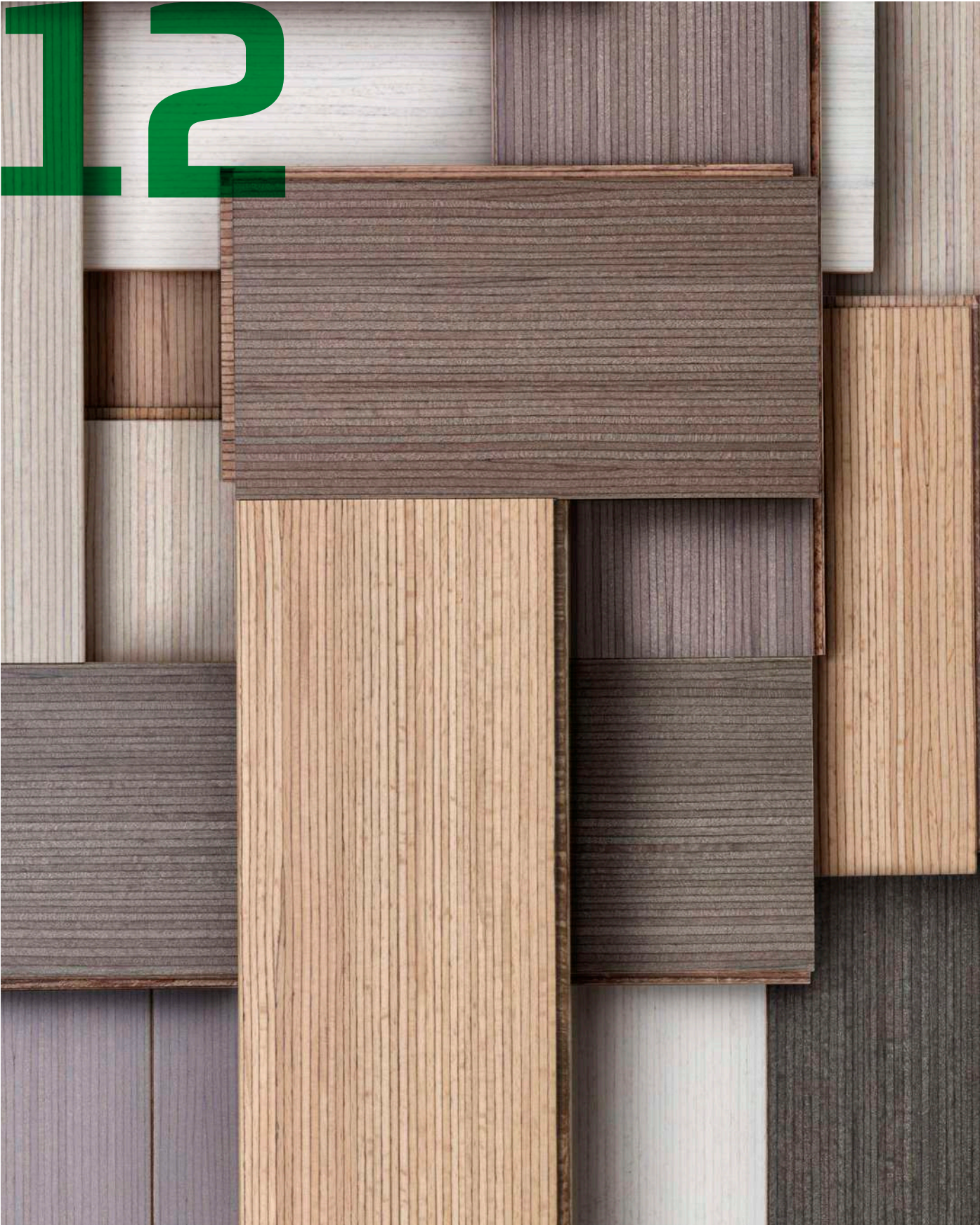

Sheet **CONTENT**

2	12.1	Resource-conserving high-tech production
3	12.2	References/visualization
5	12.3	Elements Long flooring element
6	12.4	Color Options
7	12.5	Specifications
8	12.6	Laying and Maintenance instructions
	12.6.1	General recommendations
9	12.6.2	Installation
12	12.6.3	The essentials for laying the flooring
14	12.7	Cleaning and care of hardwax-oiled floors
	12.7.1	Safety and storage instructions
15	12.7.2	Cleaning and Floorcare
	12.7.3	Re-oiling with Osmo® Hardwax-Oil
17	12.7.4	Performing minor repairs
	12.7.5	Completely sanding and re-oiling using Osmo® hardwax-oil
18	12.7.6	Further information

© Pollmeier Leimholz GmbH
Pollmeier Leimholz GmbH
Rüschfeld 131
33397 Rietberg
Germany
T +49 (0)52 44 92 05 0
rietberg@pollmeier.com
www.pollmeier.com

12.1 Resource-conserving high-tech production

Beech from sustainable forestry, peeled, laminated, pressed, tailored and finished to be a universal wooden flooring.

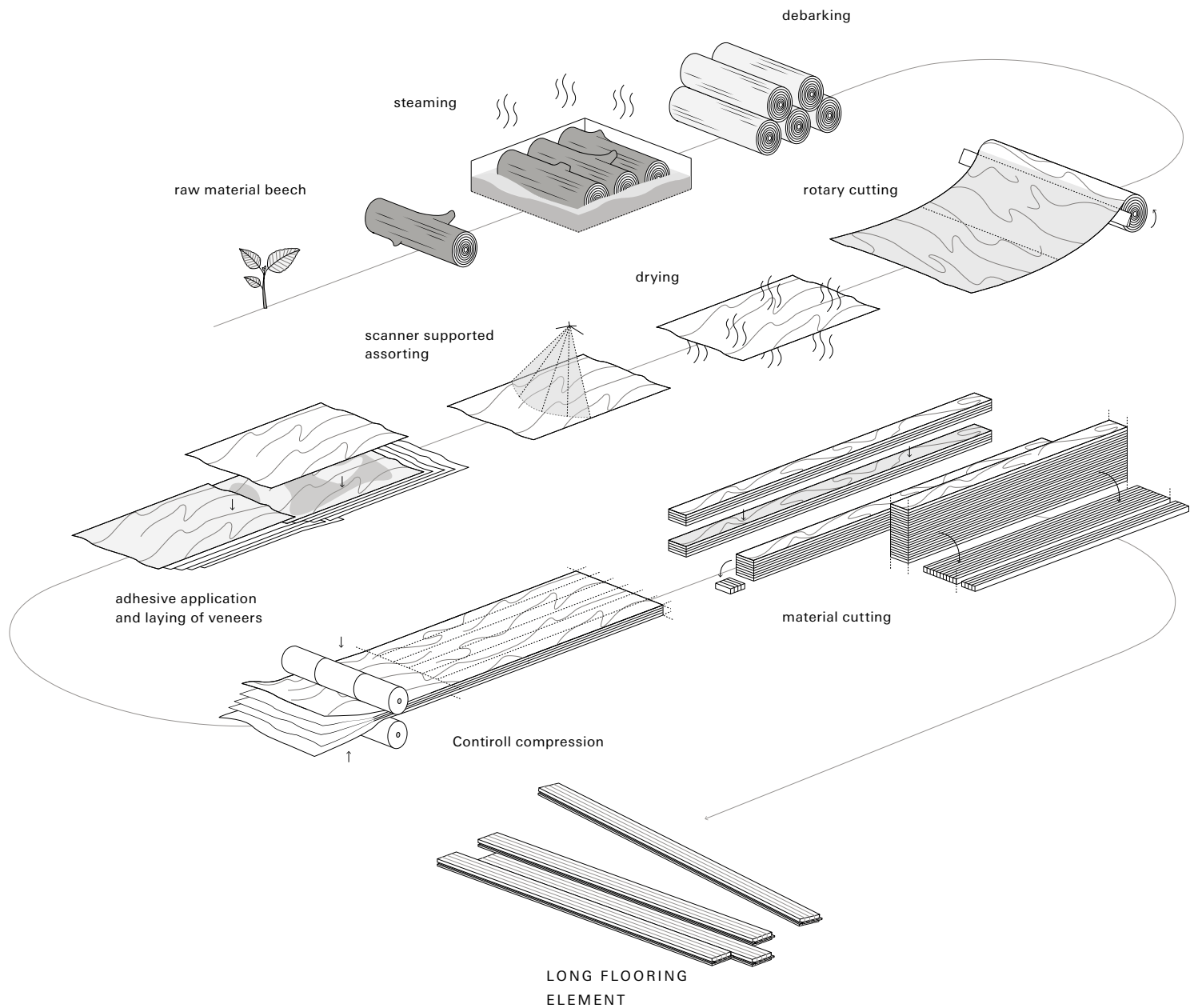

To order samples, please send an e-mail to rietberg@pollmeier.com.

12.2 Project samples / Visualization

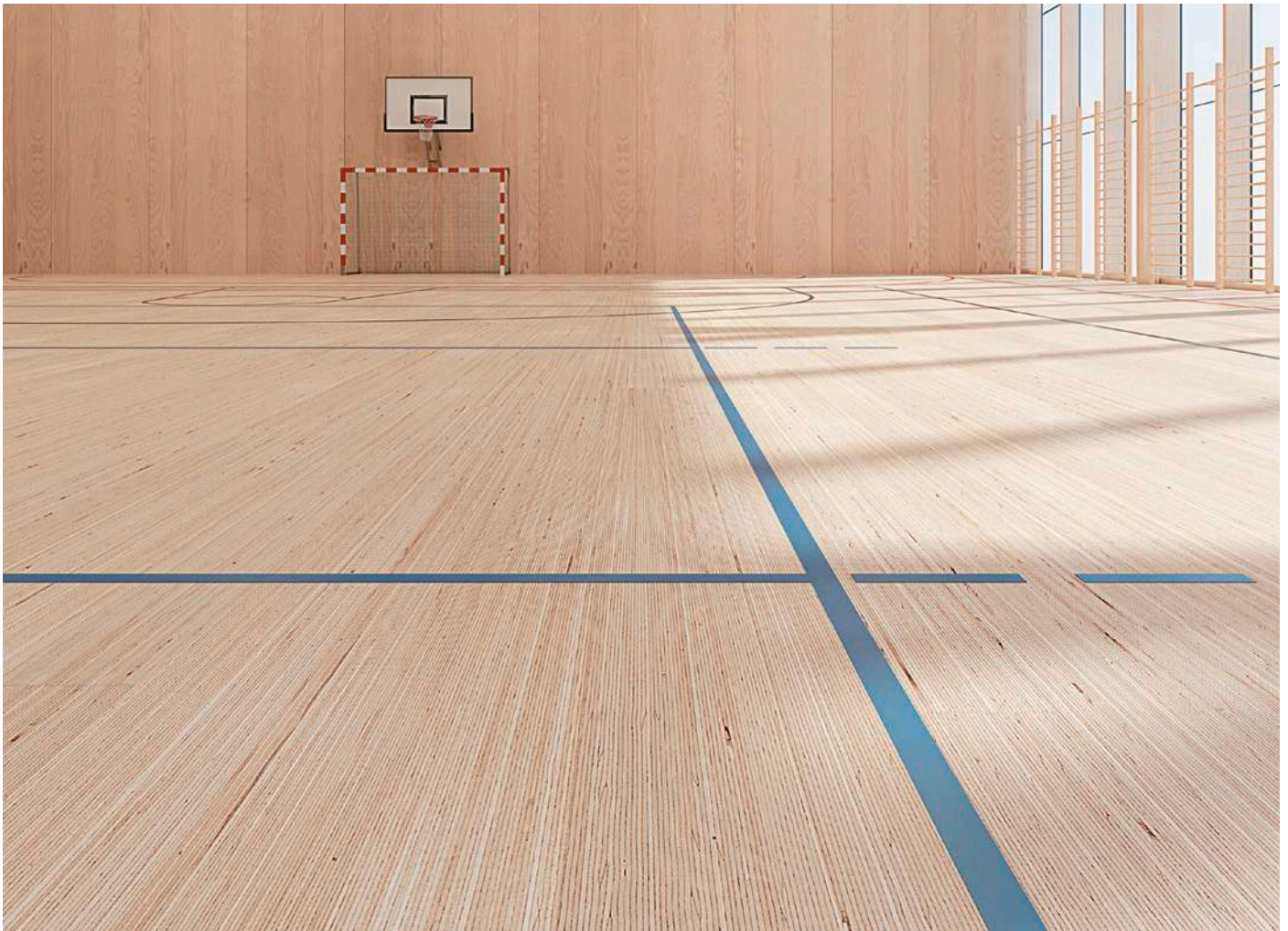

Long Flooring Element, laid at right angle Design: Architekten Hermann Kaufmann ZT GmbH

BauBuche Flooring A revolutionary development in wooden floors. **BauBuche Flooring** by Pollmeier is a natural wooden floor that shows properties which exceed anything that conventional wooden floors, hybrid products or imitations have to offer. The surface of **BauBuche Flooring** is telling us the story of its genesis. With only razor thin glued joints in-between the veneer layers are precisely strung to one another. The interplay of the iridescent tonal values and the calm texture of the beech wood give **BauBuche Flooring** a unique visual appearance. **BauBuche Flooring** unites the best properties of two worlds: the aesthetics and

the quality of its surface combined with the efficiency of a high-tech material manufactured from beech wood. **BauBuche Flooring Elements** are very robust and extremely hard (Brinell hardness $HB = 38,2 \text{ N/mm}^2$). Thanks to its durability and easy-care nature, the warm underfoot and odorless wood, and last but not least, the beautiful sound **BauBuche Flooring** will keep its value for a long time. Also the aim of an environmentally friendly production is fulfilled: **BauBuche Flooring** is produced energy and material efficiently out of a regionally grown and certified resource using state-of-the-art machinery.

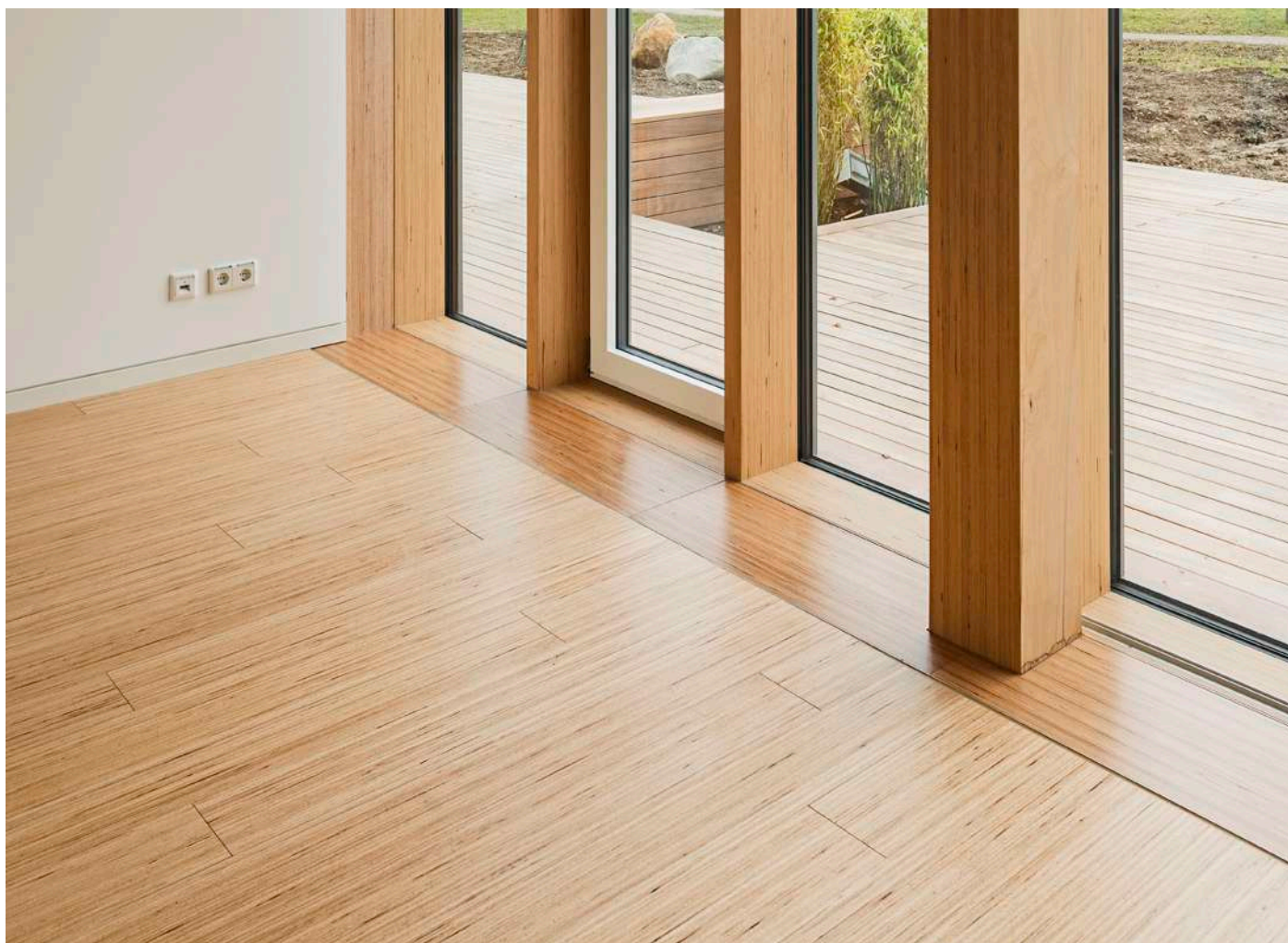

Long Flooring Element, laid at right angle Design: lattkearchitekten BDA, Augsburg

BauBuche Flooring Elements are micro-bevelled on 4 sides and come with an all around tongue and groove connection system. The accurate and dimensionally stable wood elements offer various advantages for installing the floor. They can be glued directly on screed (both thicknesses, 14mm and 20 mm) as well as nailed or screwed onto appropriate subconstructions (20 mm thickness only). **BauBuche Flooring** can be laid in virtually all environments such as apartments, nurseries, schools, museums, offices and public buildings, shops or even sports halls. The surface is sealed with environ-

mentally friendly hard wax oils or highly abrasion-proof solvent-free varnishes. **BauBuche Flooring** is available naturally-coloured or varnished with premium-quality colours in different nuances. Upon request it is also possible to receive the flooring unfinished. In this case the elements will be provided sharp-edged.

12.3 Elements

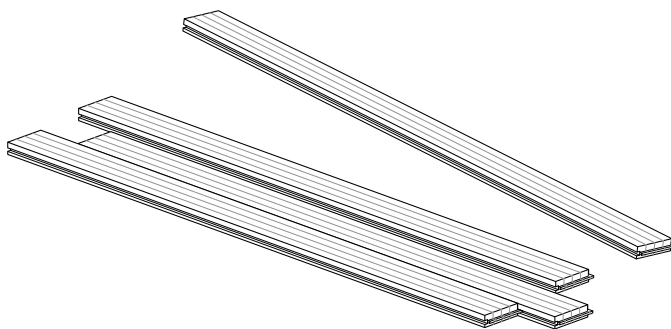

LONG FLOORING ELEMENT

(calm appearance, laid at right angle)

Surface finish with hard wax oil or finished with solvent-free varnish; unfinished

Size of elements* (comes with some short lengths)

2200 mm x 112 mm x 20 mm (7'3" x 4.4" x 3/4")

2200 mm x 112 mm x 14 mm (7'3" x 4.4" x 0.55")

2200 mm x 152 mm x 20 mm (7'3" x 6" x 3/4")

Installation glue onto screed (both thicknesses, 14 mm and 20 mm), nail or screw onto plywood boards or flooring sleepers (20 mm thickness only)

*Dimensions subject to technical alterations.

12.4 Color Options

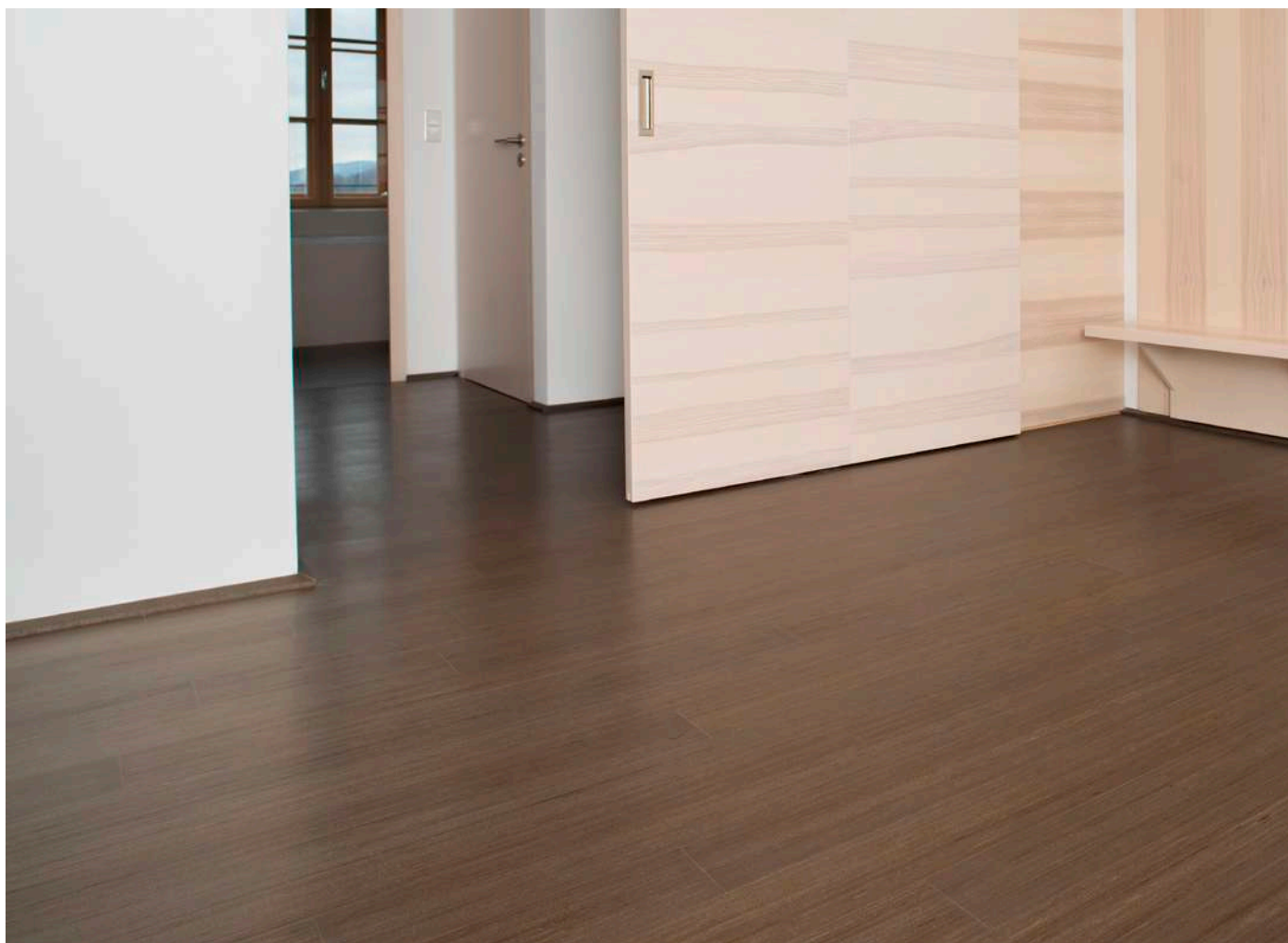

BauBuche Flooring in hotel Colour number 410, matt treated with oil



Colour 100



110



300



310



320*



400

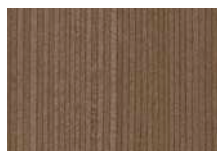

410



420*

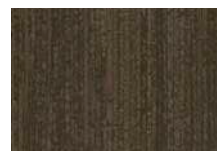

900*

*on request
for more than 500 m²

The Long Flooring Element is available in finely graduated colour nuances. Slight colour variations are possible. Our samples represent only a fraction of the possible range of shades and qualities within a delivery. We cannot exclude slight deviations in colour. In our production, we use the colours given in the published colour scale. For orders, please ensure that you quote the correct colour code.

12.5 Specifications

Product	BauBuche Flooring, long flooring element
Origin	Germany
Moisture Content	7% (+/- 1%)
Fitting Mechanism	T & G on 4 sides, nail groove (20mm thickness only)
Size of elements	2.200 mm x 112 mm x 20 mm
(comes with some short lengths)	2.200 mm x 152 mm x 20 mm 2.200 mm x 112 mm x 14 mm
Tolerances	Width: +/- 0.3 mm, along the whole length of each strip Thickness: +/- 0.2 mm Side Bend: max. 1 mm per linear foot Tolerances applicable at the date of shipment
Finishes	7 coats of solvent-free UV-curing polyacrylate, 2 of which contain aluminum oxide 3 coats of hardwax oil (based on renewable oils and natural waxes) BauBuche flooring is micro-bevelled on 4 sides Gloss Level: matte Colors: 8 colors plus Natural color We cannot exclude slight deviations in colour. In production, we use the colours given in the published colour scale. For orders, please ensure that you quote the correct colour code.
Packaging	The boards are packed in cardboard boxes. The whole pallet is wrapped in cellophane foil. Every board bears the manufacturer's marking on the back. Technical modifications are subject to change without notice.

width	thickness	sqm	boxes	sqm
in mm	in mm	per box	per pallet	per pallet
112	20	1,97	44	86,68
152	20	1,34	66	88,44
112	14	2,96	44	130,24

12.6 Laying and Maintenance instructions

12.6.1 General Recommendations

Ensure that the flooring is laid properly by a qualified specialist floor laying company. We are confident that you will be delighted with the results.

Recommendations for acclimatisation

After delivery, establish the moisture content of the BauBuche Flooring. This will provide you with a starting point for the acclimatisation measures required. Acclimatisation depends on the geographical location, room climate and the time of year. If the BauBuche Flooring is to be used in an area where the future relative humidity is 40–60%, it can be laid straight away and no acclimatisation is necessary. If the future relative humidity will be below 40% or above 60%, please contact your floor laying specialist for guidelines as regards moisture in your region. Always note the wood and air humidity at the time of laying.

The relation between wood and water

Wood is hygroscopic which means it absorbs moisture when it is exposed to a high air humidity and releases moisture or shrinks in drier environments. Thus, it continually adapts to the environmental conditions. In the worst case, the dimensions of BauBuche Flooring change by an average of 0.4% (only in terms of width) per 1% change in wood moisture. When the BauBuche Flooring leaves the factory, the wood moisture amounts to 7% (+/- 1%). This is the equilibrium humidity content for an environment with an atmospheric humidity of 45%. This means the flooring neither absorbs nor releases moisture if the humidity is maintained at 45% all year round. If the humidity is between 40% and 60%, the floor will expand or shrink slightly. Please note that this humidity value is not only ideal for the wooden flooring but is also perceived as most pleasant by individuals.

Handling and storage of the flooring

Moisture damages the flooring! For this reason, BauBuche Flooring is always packaged in specially developed boxes which preserve the original moisture content of the flooring, provided they are closed properly and not damaged. The pallet with the boxes is protected with plastic stretch film.

Nevertheless:

- _ The flooring should be unloaded during dry weather conditions.
- _ Never deliver or store the flooring in the rain, sleet or snow.
- _ Condensation should be prevented in any case.

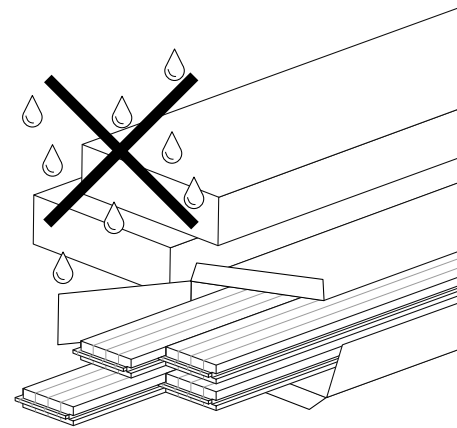
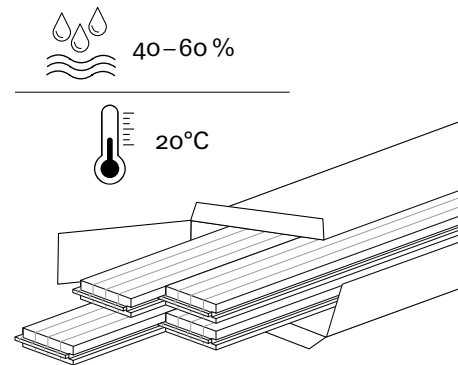

Kiln-dried flooring should be stored in a closed, well-ventilated building with weather-proof windows in areas in which similarly sensitive wood products are kept. The storage area should be clean and dry. Persistent dry heat can cause the flooring to dry out too much. If the flooring is subsequently laid without suitable acclimatisation or expansion joints, it could deform.

Conditions at the site of use

Check the site where the flooring is to be laid before delivery. The interior of the building must be dry. If the average moisture content of the subfloors, ceilings and structural elements is below 10%, the building components can be regarded as sufficiently dry.

Please ensure that the following conditions are met:

- _ The building is fully closed: all windows and outside doors have been installed.
- _ The subfloor construction for nailing has been laid.
- _ The heating/cooling system is operational (it should be ready for use at least 3 days before the floor is laid).

Floors

- _ **Upper floor:** BauBuche Flooring is suitable for laying on floors above ground level.
- _ **Ground floor:** BauBuche Flooring is suitable for laying on ground-level floors.
- _ **Cellar:** BauBuche Flooring is **not** suitable for laying on floors below ground level.

Before laying the floor, always open several boxes of the BauBuche Flooring and mix the long boards during the laying in order to get a homogeneous appearance.

12.6.2 Installation

a) Laying on a plywood concrete system

The concrete slab must be flawless, level and dust-free.

The flatness tolerance should be 5 mm over a length of 3 m.

Lay a PE film with a thickness of at least 150 µm over the entire concrete floor. Lay the film so that it rises 10–15 cm up the wall and later secure it behind the skirting board. Allow the adjacent strips of film to overlap by approx. 15 cm. With this system, plywood boards which are at least 19 mm thick are used as the subfloor. Offset the plywood end joints by half the length by cutting the first board of every second row. Place the plywood boards over the entire floor. There must be a gap of 20 mm to all wall lines and vertical obstacles and a space of 10–15 mm between the boards.

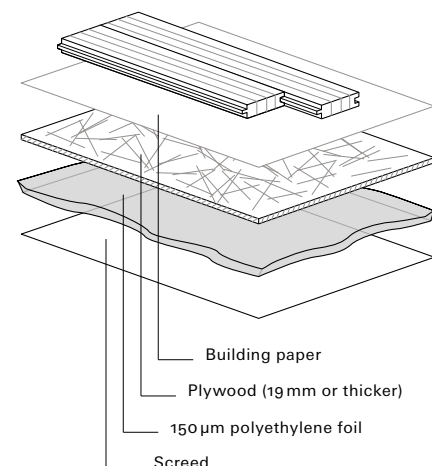
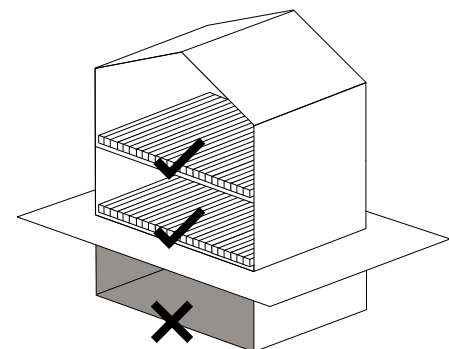
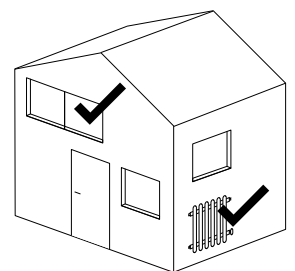

Level up the plywood boards and glue them securely to the subfloor.

Sweep the plywood floor to get rid of any dust. The flatness tolerance should be max. 5 mm over a length of 3 m. Lay out thin building paper or PE vapour-barrier sheet, making sure the edges overlap by 10 cm. Lay the ends edge to edge.

b) Installation with adhesives

The following recommendations refer to the adhesion of BauBuche Flooring to concrete floors. If you want to glue the flooring to lightweight concrete or self-levelling filler, contact the adhesive manufacturer in advance.

Various adhesive manufacturers carried out product tests with BauBuche flooring, e.g. Sika AG (suitable for full-surface adhesion is for instance T-54 or the AcouBond system, which satisfies the requirements in terms of sound attenuation), Mapei GmbH (Ultrabond Eco Sg68 1K or alternatively Ultrabond Eco P909 2k), Wakol GmbH (various products) and Stauf Klebstoffwerk GmbH (SPU570 or PUK446 and PUK455). Please contact these companies for more information about which adhesive is most suitable for your application.

Prepare the concrete floor for adhesion as per the adhesive manufacturer's recommendations. The concrete base must be clean, dry and dust-free (vacuum-cleaned). The flatness tolerance should be max. 5 mm over a length of 3 m. Get the moisture content checked by the foorer. The maximum moisture content for concrete screed should be $\leq 1,8\%$, for calcium sulfate screed $\leq 0,3\%$ (measured by CM-method). For additional moisture protection we recommend use of a primer (e.g. Sika Primer MB) as per the adhesive manufacturer's recommendation.

Check the conditions at the site and ensure that the room temperature is around 20°C. The floor should be laid in a temperature controlled environment.

Lay the first BauBuche Flooring board at a distance of 20 mm from the wall and with the grooved side facing the wall. Mark the position of the tongue on the subfloor in both corners of the room. Draw a chalk line between the two markings and use a finishing spatula as per the adhesive manufacturer's instructions to apply the adhesive up to the chalk line. Now adhere the first board row with the tongue flush with this line. Then lay another 3 or 4 more rows and allow to dry overnight. The exact positioning and straight alignment of the first rows are very important here. We recommend the use of lashing straps.

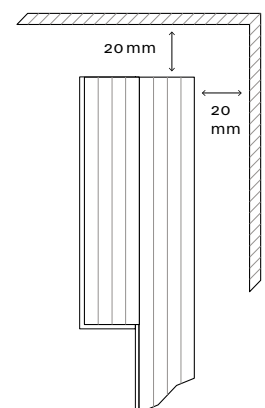
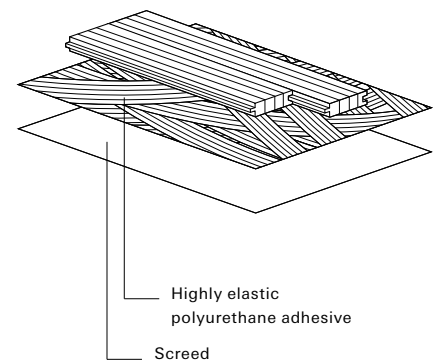
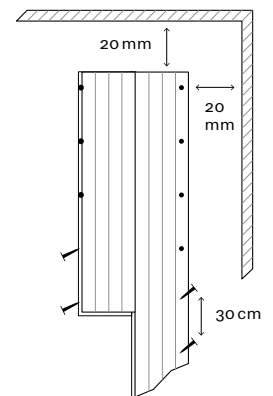

Use standard lashing straps every 4 to 8 rows to keep the boards together. Place the straps approx. every 45 to 60 cm to secure both the middle and ends of the individual boards in the last row.

Lashing straps should be used whilst the adhesive is still moist and has not yet hardened. If necessary use weights when securing the boards with straps to keep the floor boards on the floor.

To achieve a homogeneous look, lay 7 to 8 loose rows of BauBuche Flooring edge against edge and in an offset pattern making sure to leave a distance of at least 30 cm between the end joints. Always offset the end joints of the individual boards by at least 15 cm, making sure to avoid H joints.

Now apply the adhesive as usual. The boards can then be adhered in the pattern which was previously set out. Use a rubber mallet and a bar to insert the tongues into the board grooves. If the boards do not fit, cut them and use them as a starting or end piece.

Lay the flooring in the entire room, and just as with the first row, leave a gap of 20 mm to the opposite wall. In rooms with a very high level of humidity we recommend the use of spacers (e.g., coins) when laying the rows to allow the floor to expand.

c) Laying on a timber beam construction

Ensure that there is good transverse ventilation below the planned BauBuche Flooring (e.g., by offset vertical beams). A surface cover above a crawl space made up of a polyethylene film at least 150 µm thick is essential to act as a moisture barrier.

Both plywood boards with a thickness of 16 or 19 mm as well as 20-mm-thick OSB boards are suitable as a subfloor. As far as possible, thinner materials should not be used as a subfloor.

Lay the subfloor boards as per the manufacturer's recommendations. Unless the board manufacturer recommends otherwise, the grain sides should be installed at a right angle to the wooden beam construction and secured every 15 cm to this construction using suitable screws. A corresponding distance should be maintained at the board ends and edges.

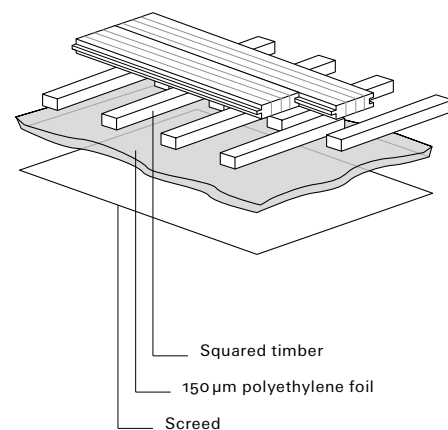

With a subfloor made of old boards, only use flat, dry and angular beams which are not wider than 15 cm. They are to be laid at right angles to the wooden beam construction. Expansion joints of 6 to 10 mm should be provided between the boards. Do not use groove and tongue boards. Each contact point should be secured with two 8d nails. All the joints should be located on the wooden beam construction. Mark the position of the wooden beams so that the flooring can be secured to these. Take care in applying the nails to ensure the boards stay in position. If the nails are not put in properly the flooring can end up squeaking.

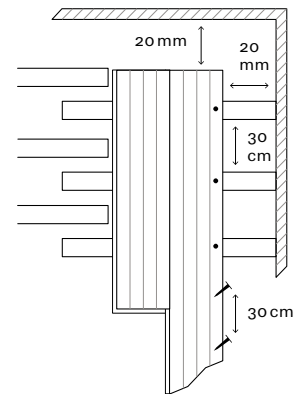

12.6.3 The essentials for laying the flooring

Laying direction

Always lay the BauBuche Flooring in the direction of the longest room/building dimension. If a hallway runs parallel to the longest room dimension, to start off draw a chalk line along the middle of the hallway and work from that point into the room. Use a parquet tongue to change the laying direction if the hallway is to be laid at a later date.

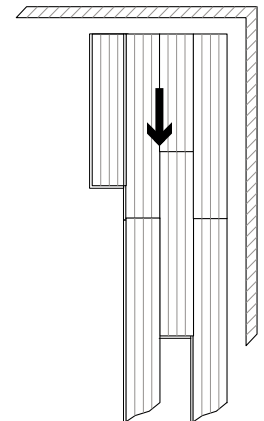

Preparing to lay the flooring

Arrange three BauBuche Flooring boards, edge to edge, so that the joints are offset, making sure to leave at least 30 cm between the end joints. Mix the boards from different packages in order to achieve a homogenous laying pattern. Offset the end joints of individual boards and in subsequent rows by at least 15 cm. Avoid H-joints.

Push together the tongue and groove of each board and secure the tongue with a nail. Drive in all the nails. Once you have laid the first or second row, you can change from using a hammer to a soil nailing machine with serrated nails (38 mm or 44.5 mm).

Nail down the nails at the correct angle in the nail groove of the flooring. Position the boards of the next row by inserting the groove into the tongue of the already laid row. Now nail down each board at intervals of 20 cm and near to the end joints through the nail groove. Lay the flooring in the entire room, and just as with the first row, leave a gap of 20 mm to the opposite wall. Do not insert nails into the joints of the underfloor construction. If the room is more than 6 m wide, provide for an additional expansion joint of 20 mm every 3 m.

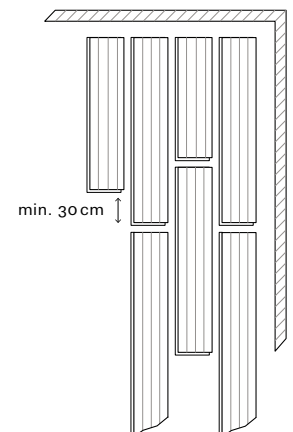

To allow for possible additional expansion, we recommend distributing spacers evenly over the flooring if the area to be laid is wider than 6 m and expansion is anticipated (depending on the expected expansion of the respective environment). In the case of adjacent joints, place a spacer on each side of the joint and every 30 cm along the length. It may not be necessary to use additional spacers in all areas.

Starting to lay the flooring

The exact positioning and straight alignment of the first row are very important. Lay the BauBuche Flooring board 20 mm away from the starting wall with the grooved side facing the wall and draw a dot on the underfloor on the edge of the board tongue. Do the same in both corners of the room and draw a line in chalk between the two dots. Nail down the first board with the tongue on this line. The gap between the board and wall is necessary to allow expansion and is subsequently hidden by the skirting boards. Lay the first row with the groove facing the wall and the tongue flush with the chalk line you drew at the start. Nail down the 8d nails at the ends of the boards at a distance of 20 mm from the wall and at every 30 cm. (The skirting board hides the nail heads). Fix the other boards in the first row in the same way.

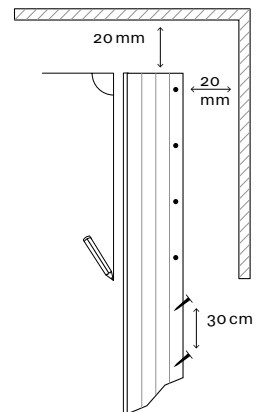

Skirting boards

Attach the skirting boards to the wall - and not to the flooring - once the entire floor has been laid.

- _ **Work from left to right.** BauBuche Flooring is easier to lay if you work from left to right.
- _ **Shorter lengths.** To achieve improved aesthetics, always use long deck boards in entrance areas and around doors. Use the shorter lengths or the remainder of cut boards from the previous row as the first piece in the subsequent row.
- _ **Changing the direction of BauBuche Flooring.** It is sometimes necessary to change the direction of the flooring at the entrance to a new room or hallway. To do this, connect the grooved sides using a special wedge-shaped insert (parquet tongue which is adhered into the groove). Nail down as usual.

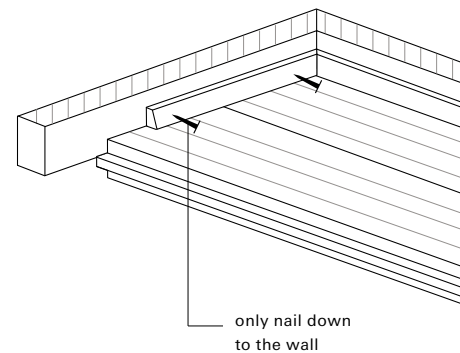

12.7 Cleaning and care of hardwax-oiled floors

12.7.1 Safety and storage instructions

Before you do any step please read carefully all safety and storage instructions of all products and machines recommended by Pollmeier. All safety and storage instructions of the products' and machines' manufacturer must be followed.

Liquid Wax Cleaner

- _ 1 liter can: Keep out of the reach of children. In case of contact with eyes, flush thoroughly with water immediately and seek medical help. Ensure proper ventilation during work. The product is igniting.
- _ 0,4 liter spray can: The container is under pressure and must be protected from sunlight and temperatures over 50 °C (122 °Fahrenheit). Even after use do not open by force, tap or burn. Do not spray against flame or incandescent item. Keep away from ignition sources. Do not smoke. Do not inhale the aerosol. Use only in well-ventilated areas. Gas: propan/butan. The product is highly-igniting. Give only completely empty cans to recycling.

Stain

Should be stored at a temperature between 5 and 30 °C (41 and 86 °Fahrenheit), and must be kept away from heat sources, direct sunlight, and ignition sources.

Hardwax-Oil

Keep out of the reach of children. In case of contact with eyes, flush thoroughly with water immediately and seek medical help. Do not work near an open flame. Product contain 2-butanone, which may produce allergic reactions. Cloths, polishing pads, floor brush or brush which have been soaked with the liquid product must be washed out or kept in an air-tight container after use, since they otherwise present a danger of spontaneous combustion.

Three-Disc Floor Buffing Machine

Please observe the safety instructions of the machine's manufacturer. Always empty the machine's dust bags immediately after finishing work due to the possible danger of spontaneous combustion.

Cleaning of the Tools

All tools can be cleaned with benzene-free Osmo® Brush Cleaner or mineral spirits.

Warranty disclaimer

No warranty exists with respect to Pollmeier's wood products, except for manufacturing defects. Pollmeier offers a limited warranty for its finish and does not offer a warranty for its hardwax-oil finish. Pollmeier warrants that its finish will be free from defects in material or manufacture. Pollmeier warrants its floor finish for 25 years under normal residential traffic conditions and 3 years under light commercial conditions, as described in Pollmeier's website. Pollmeier's warranty is applicable only to the original owner of its prefinished wood products. Pollmeier's warranty is limited to providing the original owner with repair, refinish, or replacement of the finish, at Pollmeier's sole discretion. For further information and up to date information regarding Pollmeier's warranty disclaimers, exclusions, installation instructions and requirements, and conditions, please visit www.pollmeier-flooring.com

12.7.2 Cleaning and Floorcare

With proper attention to cleaning and maintenance, a natural wood floor can be enjoyed for many years.

Special care is required for heavily used natural floors in restaurants, offices, department stores or public buildings to ensure long-lasting, beautiful floors. Protective steps such as using felt pads under chairs and other furniture in order to avoid scratches, as well as floor mats for wheelchairs, is worthwhile. The cleaning and maintenance intervals in areas such as these should be more frequent than in the home.

Daily cleaning can be done with a broom, a vacuum cleaner or with a commercially available dust mop.

For damp cleaning, we recommend Osmo® Wash and Care. Areas of heavy traffic, as described above, should be damp cleaned daily. In the home, it is sufficient to apply Wash and Care once a week.

Please note: Wood floors must be damp wiped, not wet wiped. A commercially available mop is also ideal for this purpose.

To remove any stubborn spots you can use the Wax Cleaner 3029. Simply apply the cleaner using a cloth or buffing pad, rub the floor and wipe up the dissolved dirt.

Before a floor completely loses its shine it can be refreshed using Liquid Wax Cleaner 3029. Just apply the cleaner undiluted with a lint-free cloth onto the cleaned floor and spread extremely thinly (2 teaspoons per 10 sqft/1 m² is enough). For larger surfaces, a commercially available active fiber cloth would be suitable. In restaurants this application is recommended as much as once a week; otherwise floors should be refreshed as needed.

12.7.3 Re-oiling with Osmo® Hardwax-Oil*

If there are visible signs of wear, which are not serious enough to require sanding the surface, the floor should be re-treated with Osmo® Hardwax-Oil. We recommend article # 3062 matt finish for BauBuche flooring or # 3065 semi-matt finish for solid wood flooring (US market # 3054). When and how often a floor finished with Osmo® Hardwax-Oil must be re-oiled depends, for one, on how much traffic this natural floor is exposed to, and for another, on how regularly the floor is cleaned and maintained. One factor that makes re-oiling the floor necessary is the appearance of wear in areas of heavier traffic.

Private Households and Smaller Areas

— The area of the floor you want to oil must first be thoroughly cleaned, dried, and free of dust.

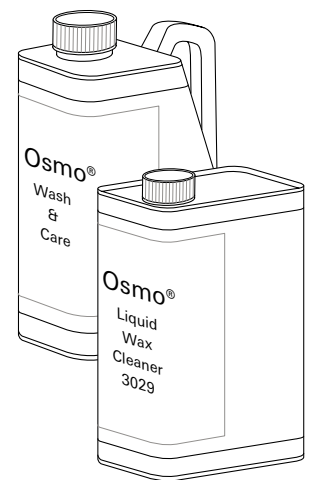

Danger!

Harmful or fatal if swallowed. Call physician immediately if ingested.

Caution

Flammable/Combustible. Keep away from open flame and other ignition sources.

Caution

May cause respiratory tract irritation. May cause skin irritation. May cause eye irritation. Avoid contact with eyes, skin and clothing. Read carefully and follow instructions on package.



* Osmo® Hardwax-Oil is not a product of Pollmeier.

_ Osmo® Hardwax-Oil is applied with a floor brush, or a stiff, densely-packed natural-hair brush, onto the clean and dry wood surface. Then spread thinly and thoroughly in the direction of the grain of the wood. Ensure that the oil is always applied thinly and cleanly. Remove any excess with a lint-free cloth. Let the oiled floor dry for 12 hours at 20°C (68°Fahrenheit) ensuring proper ventilation. Always follow manufacturer instructions on the product label.

_ Repeat step 2. The floor can be walked on again after being allowed to dry for 12 hours at 20°C (68°Fahrenheit) ensuring proper ventilation. High levels of humidity may result in longer than normal drying time.

Note: The finish is not completely cured until 10 to 14 days after application. During this curing phase you should not put down any carpeting or, as in the course of upkeep, apply any dampness to the surface. Cover areas of heavy traffic with corrugated cardboard, with the corrugated side facing the floor to permit better ventilation.

Commercial and Public Use Areas

_ The area of the floor you want to oil must first be thoroughly cleaned, dried, and free of dust.

_ Osmo® Hardwax-Oil is applied with a floor brush or a stiff, densely-packed natural-hair brush, onto the clean and dry wood surface. Then spread the applied oil evenly across the surface with a Lägler Trio three-disc floor buffing machine*, or an equivalent spreading machine, outfitted with three white polishing pads without any grit.

_ Remove polishing pads and fit the brush heads onto the appropriate receptacles on the machine. The rotating brushes allow the oil to penetrate all the depressions as well as the bevels along the lengths and the ends of the boards and spread any puddles evenly over the floor. Let the oiled floor dry for 12 hours at 20°C (68°Fahrenheit) ensuring proper ventilation.

_ Repeat steps 2 and 3. The floor can be walked on again after being allowed to dry for 12 hours at 20°C (68°Fahrenheit) ensuring proper ventilation. High levels of humidity may result in longer than normal drying time. Once the floor is properly dried, it is generally inflammable.

Note: The finish is not completely cured until 10 to 14 days after application. During this curing phase you should not put down any carpeting or, as in the course of upkeep, apply any dampness to the surface. Cover areas of heavy traffic with corrugated cardboard, with the corrugated side facing the floor to permit better ventilation.

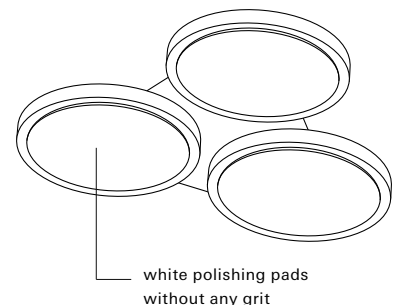
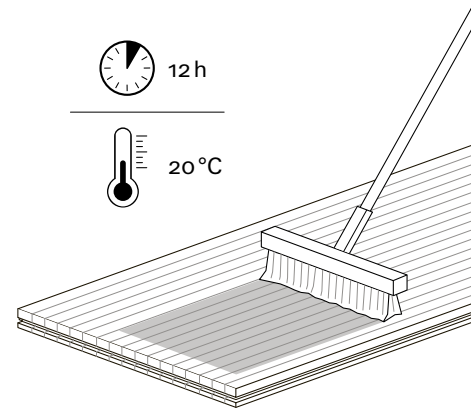

* This is not a Pollmeier product

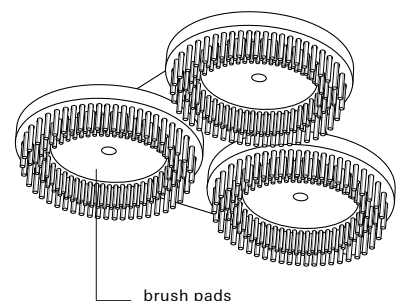

12.7.4 Performing minor repairs

- _ Sand the spot you would like to repair using a sanding sponge with 180-grit to restore it to the raw wood surface. Smooth out any roughness created by the 180-grit paper in the area surrounding the spot to be repaired using 400-grit paper.
- _ Apply stain with a cloth directly on the prepared surface and allow sufficient time for the stain to dry. Wipe the stained surface with a damp cloth and ensure color uniformity. If the tone is too light, repeat with another application until a match is achieved.
- _ When the color match is achieved apply Osmo® Hardwax-Oil with a clean cloth to the stained area, let it dry for 12 hours at a temperature of 20 °C (68 °Fahrenheit) ensuring proper ventilation.
- _ Once properly dried, apply Osmo® Hardwax-Oil with a cloth for a second time. If you are not fully satisfied with the result, the process may be repeated.
- _ The floor can be walked on again after it has dried for 12 hours at 20 °C (68 °Fahrenheit) ensuring proper ventilation. High levels of humidity may result in longer drying time. Once the area is properly dried, it is generally inflammable.

Note: The finish is not completely cured for 10 to 14 days after the repair was performed. During this curing phase it is inadvisable to lay carpeting on the area or apply any damp material (including mopping) on the repaired surface. Cover areas of heavy traffic with corrugated cardboard, with the corrugated side facing the floor to permit better ventilation.

12.7.5 Completely sanding and re-oiling BauBuche Flooring using Osmo® Hardwax-Oil

During the application process be sure to follow all product-handling instructions contained on the on the product label.

The right amount of smoothness is the basic prerequisite for how the surface will look later. You can achieve this by sanding from rough to fine, and from large to small. Whenever possible, you should always sand in the direction of the wood grain. Depending on the damage to the surface you can start with the Lägler Trio three-disc floor buffing machine, or an equivalent spreading machine, outfitted with three 80-grit sandpaper discs.

Areas of the floor that are inaccessible with the Lägler Trio can be sanded using the Lägler Flip or an equivalent sanding machine designed to sand along edges.

The second and third sanding should be done with 100-grit or 120-grit paper.

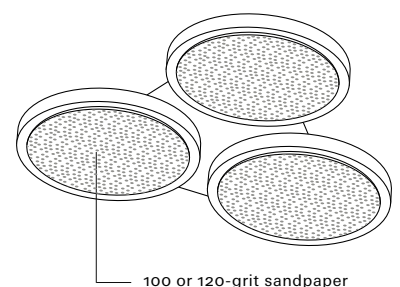
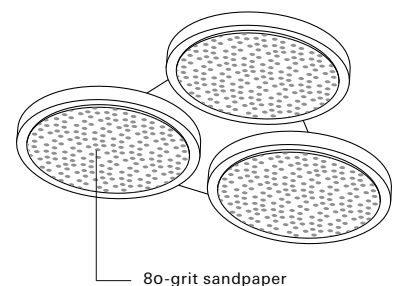
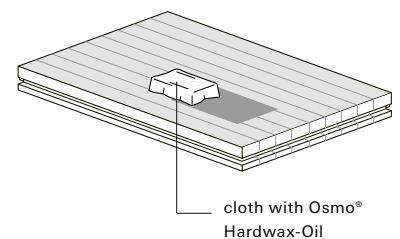
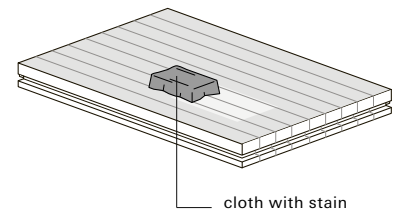
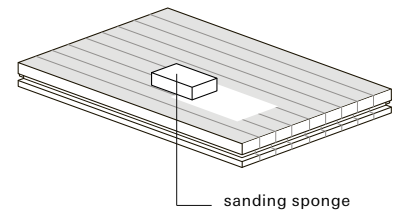

After the third sanding, we recommend mending any knots, cracks or defective spots with wood filler. The wood filler can be applied with a putty knife and can be sanded down after it has dried for the time period specified by the manufacturer.

The final sanding is done in the same way, but with 150-grit paper.

The wood floor must be completely clean and free of sanding dust before any further work is carried out.

Apply the first coat of Osmo® Hardwax-Oil. Osmo® Hardwax-Oil is applied with a floor brush, or a stiff, densely-packed natural-hair brush, onto the clean and dry wood surface. Spread thinly and thoroughly in the direction of the grain of the wood. Ensure that the oil is always applied thinly and cleanly. Remove any excess with a lint-free cloth.

Let the oiled floor dry for 12 hours at 20°C (68°Fahrenheit) ensuring proper ventilation.

Apply the second coat of Osmo® Hardwax-Oil. Apply Hardwax-Oil as described above with the floor brush or a stiff, densely-packed natural-hair brush. Then spread the applied oil evenly across the surface with a Lägler Trio three-disc floor buffing machine or an equivalent spreading machine outfitted with three white polishing pads without any grit.

Remove the polishing pads and fit the brush heads onto the appropriate receptacles of the machine. The rotating brushes get into all the depressions as well as the joints along the lengths and the ends of the awalked on again after it has dried for 12 hours at 20°C (68°Fahrenheit) and with plenty of ventilation. If the humidity is high, the drying process may take longer.

Note: The finish is not completely cured until 10 to 14 days after application. During this curing phase you should not put down any carpeting or, as in the course of upkeep, apply any dampness to the surface. Cover areas of heavy traffic with corrugated cardboard, with the corrugated side facing the floor to permit better ventilation.

12.7.6 Further information

There are several videos in our media centre on www.osmo.de, providing useful information about the various OSMO® products. The menu item "wood coatings, indoor" features up-to-date information on the various wood care products.

